

Type: CE = Single Inlet

Performance / Dimensions



Type: CE 790/D 500 [400V 3N~ 50 Hz]
Protection type: IP 65

Please state intake side !
For sound data please see extra pages.

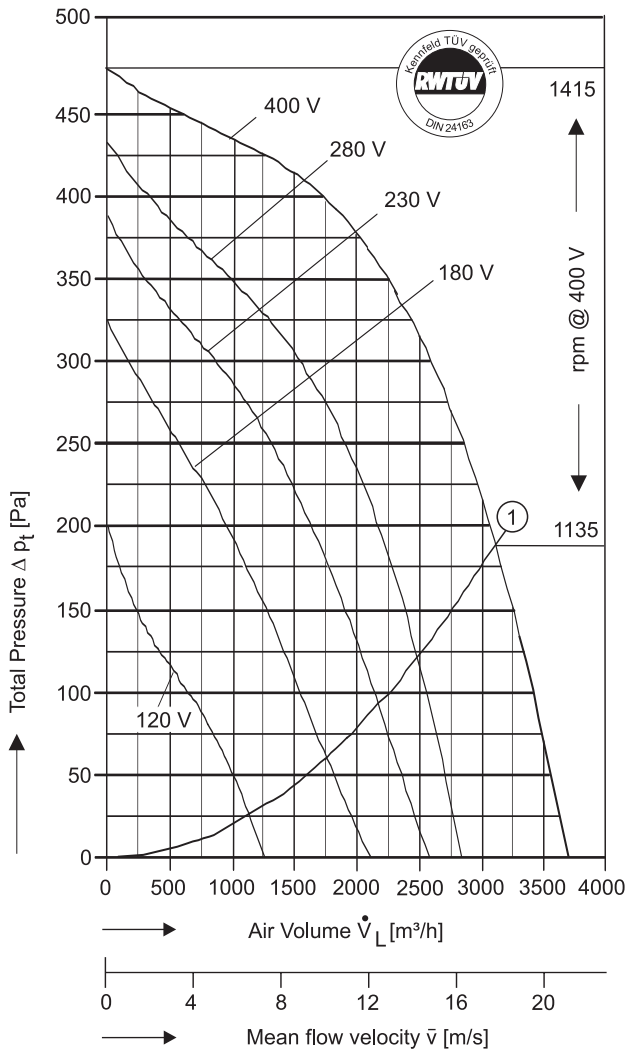

$P_{max} = 1,092 \text{ kW}$ $I_A / I_N = 1,7$ $I_{max} = 2,50 \text{ A}$

① System curve for dynamical pressure part related to fan discharge surface of 0,0479 m². For operating points above that curve a max. air temperature of 60° C is allowed (Curve for free blowing fan).

Voltage [V]	Air Volume \dot{V}_L [m ³ /h] at $\rho = 1,2 \text{ kg/m}^3$ and current [A] (bold figures, 2nd. line)							
	Free Air	Total Pressure Δp_t [Pa]						
		100	150	200	250	300	350	400
120	1195 1,14	576 0,98	220 0,89					
180	1752 1,54	1540 1,45	1275 1,34	946 1,23	590 1,10			
230	2174 1,77	2140 1,72	1898 1,65	1635 1,54	1275 1,41	908 1,28	400 1,14	
280	2470 1,94		2386 1,90	2175 1,81	1896 1,70	1483 1,57	997 1,43	350 1,28
400	3113 2,50			3113 2,50	2834 2,40	2536 2,32	2247 2,26	1752 2,16

Save power and even more silent with FISCHBACH SPEED CONTROLLERS FISCHBACH AUTOMATIC CONTROLLERS

Voltage Control	Type*	Order-No.*
Stepless, 0 - 100% and 100% - 0	FDR55/3	6231
Stepwise, 5 Steps	FDR2.75/3	6181
FISCHBACH AUTOMATIC CONTROL **	FRA 55/3	6281
Frequency Inverter FFU	on request	

* For further details see resp. catalogue pages
** For details of sensors etc., on request

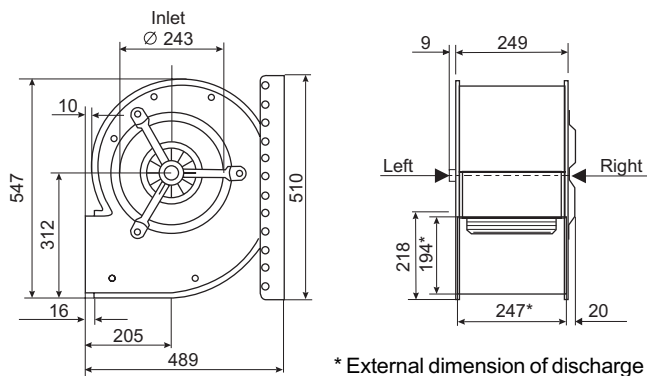

* External dimension of discharge



The Silent One

In the above diagram the **TOTAL** pressure (the sum of the dynamic and static pressures) is shown in relation to the air volume, dynamic pressure is shown below system line No.1. Static pressure is shown above that line.