

Type: CE = Single Inlet

Performance / Dimensions



Type: CE 890/D 1 [380V 3N~ 60 Hz]
Protection type: IP 65

Please state intake side !
For sound data please see extra pages.

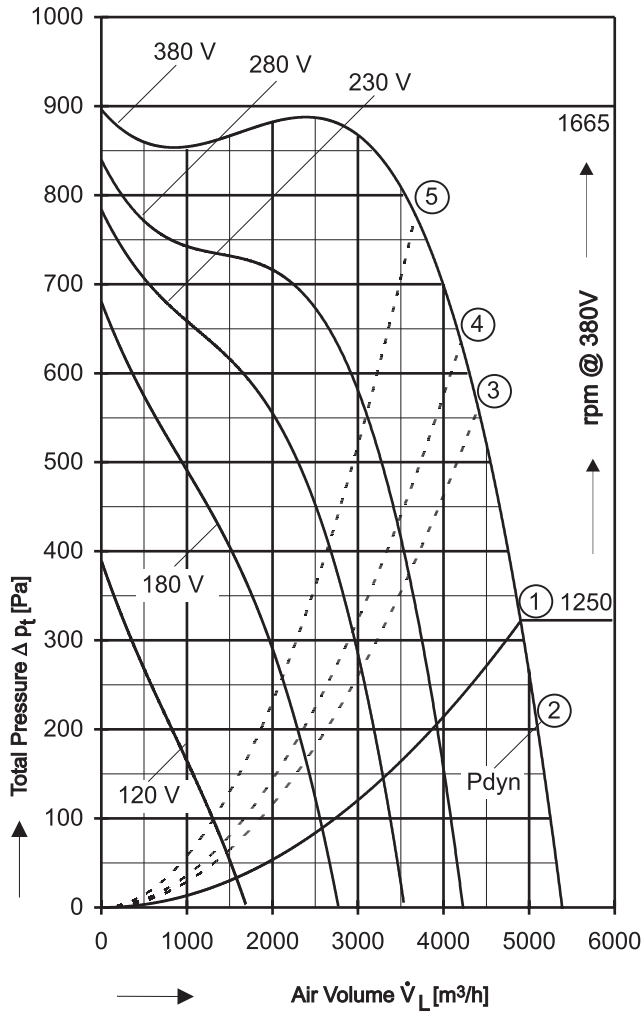

Voltage [V]	Air Volume \dot{V}_L [m³/h] at $\rho = 1,2 \text{ kg/m}^3$ and current [A] (bold figures)						
	Free Air	Total Pressure Δp_t [Pa]					
		200	300	400	500	600	700
120		825 2,68	355 2,43				
180			1965 3,67	1525 3,29	945 2,82		
230			2960 4,51	2680 4,21	2300 3,82	1655 3,23	
280				3535 4,86	3275 4,58	2920 4,22	2245 3,61
380						4300 5,20	3995 4,93
							3555 4,57

Save power and even more silent FISCHBACH SPEED CONTROLLERS Manual and Automatic		
Voltage Control	Type*	Order-No.*
Stepless 0 - 100% and 100% - 0	FDR 55/3	6231
Stepwise 5 Steps	FDR 5.5/3	6172
FISCHBACH AUTOMATIC CONTROL **	FRA 55/3	6281

* For further details see resp. catalogue pages
** For details of sensors etc., on request

- ① Free air relating to fan discharge area 0,0235 m².
- ② Velocity (dynamic) pressure
For Static Pressure Regain see example
- ③ Max. permissible ambient temperature 25°C.
- ④ Max. permissible ambient temperature 30°C.
- ⑤ Max. permissible ambient temperature 40°C.

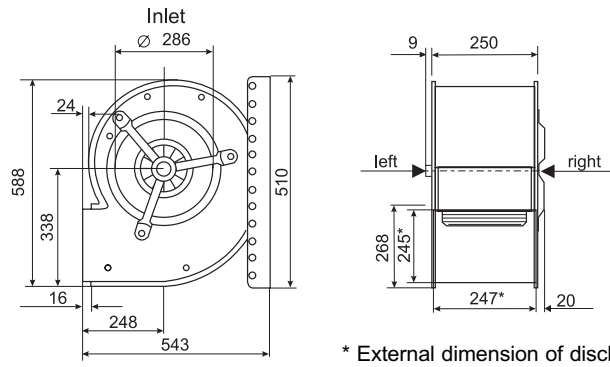

* External dimension of discharge



The Silent One