

**Type: CFE = Single Inlet "Superflat"**

**Performance / Dimensions**



**Type: CFE 840/E 35 [220V 1N~ 60 Hz]**  
 MP Capacitor 25 µF - 400 VDB  
 Protection type: IP 65

Please state intake side !  
 For sound data please see extra pages.

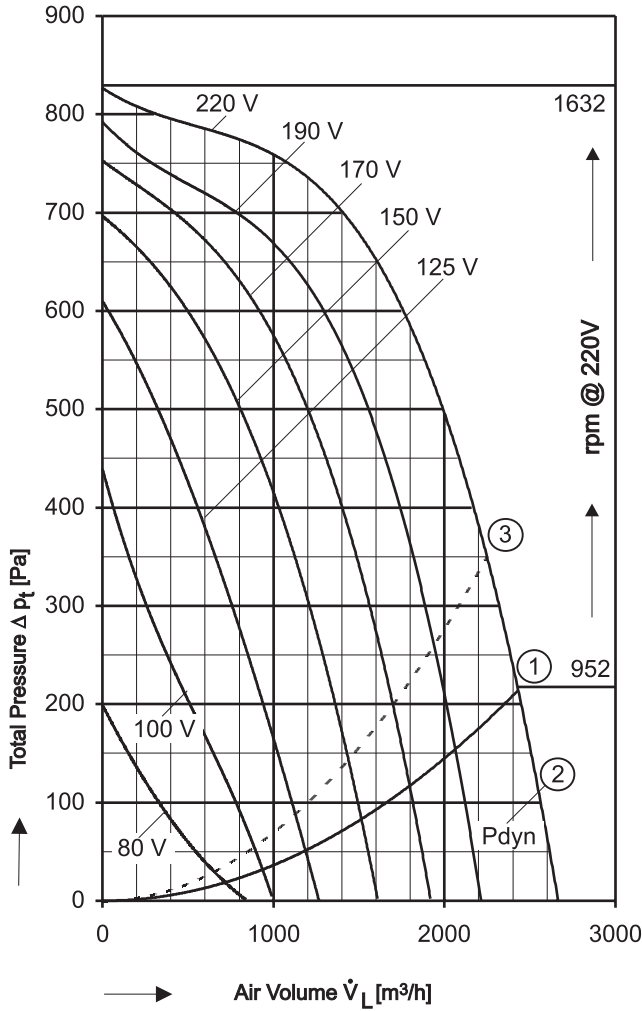

- ① Free air relating to fan discharge area 0,0357 m². Max. permissible ambient temperature 50°C.
- ② Velocity (dynamic) pressure  
For Static Pressure Regain see example
- ③ Max. permissible ambient temperature 60°C.

Voltage [V]	Air Volume $\dot{V}_L$ [m³/h] at $\rho = 1,2 \text{ kg/m}^3$ and current [A] (bold figures)							
	Free Air	Total Pressure $\Delta p_t$ [Pa]						
		100	200	300	400	500	600	700
80	710 <b>2,16</b>	325 <b>2,11</b>						
100	930 <b>2,68</b>	780 <b>2,65</b>	510 <b>2,58</b>					
125	1185 <b>3,41</b>	1110 <b>3,35</b>	940 <b>3,24</b>	760 <b>3,12</b>	560 <b>2,98</b>			
150	1515 <b>4,06</b>	1495 <b>4,04</b>	1360 <b>3,91</b>	1210 <b>3,77</b>	1030 <b>3,61</b>	810 <b>3,42</b>		
170	1795 <b>4,54</b>		1700 <b>4,43</b>	1565 <b>4,28</b>	1400 <b>4,10</b>	1200 <b>3,89</b>	920 <b>3,62</b>	
190	2060 <b>4,99</b>		2010 <b>4,93</b>	1890 <b>4,77</b>	1740 <b>4,59</b>	1555 <b>4,37</b>	1295 <b>4,09</b>	785 <b>3,58</b>
220	2430 <b>5,55</b>			2320 <b>5,40</b>	2170 <b>5,21</b>	1990 <b>4,97</b>	1760 <b>4,69</b>	1410 <b>4,28</b>

Save power and even more silent FISCHBACH SPEED CONTROLLERS Manual and Automatic		
Voltage Control	Type*	Order-No.*
Stepless 0 - 100% and 100% - 0	FDR 55	<b>6163</b>
Stepwise 7 Steps	FDR 750	<b>6202</b>
FISCHBACH AUTOMATIC CONTROL **	FRA 55	<b>6252</b>

\* For further details see resp. catalogue pages  
 \*\* For details of sensors etc., on request

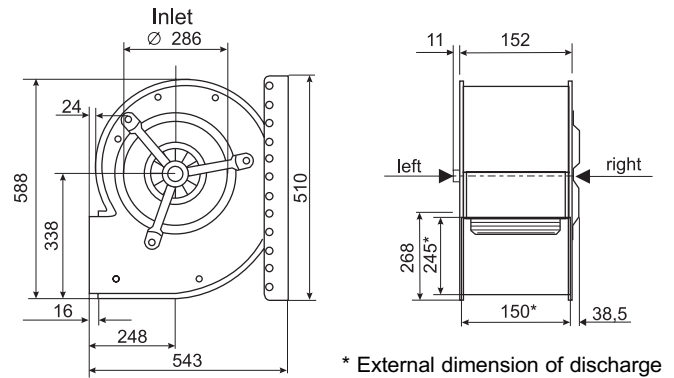

The Silent One