

Type: D = Double Inlet

Performance / Dimensions



Type: D 640/E 35 [230V 1N~ 50 Hz]

MP Capacitor 25 µF - 400 VDB
Protection type: IP 65

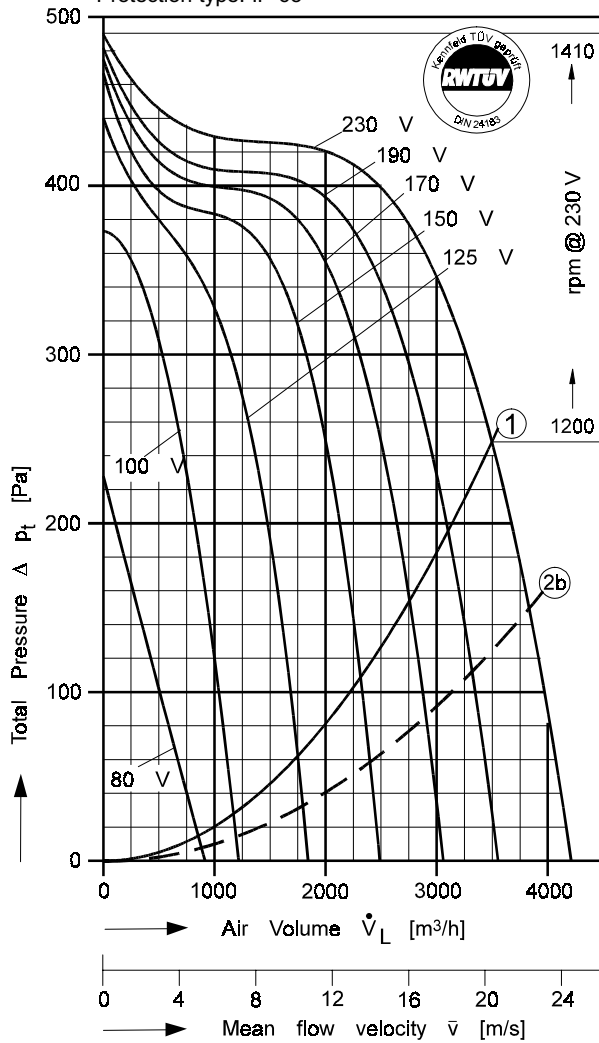

P_{max} = 1,05 kW I_A / I_N = 1,7 I_{max} = 4,72 A

- ① **System curve for dynamical pressure part related to fan discharge surface of 0,0478 m². For operating points above that curve a max. air temperature of 70° C is allowed (Curve for free blowing fan).**
- ② **System curve incl. pressure regain by means of DIFFUSER ANGLE FRAME (FISCHBACH accessory) with connected duct. Duct length: 1,7 m.**

For sound data please see extra pages.

Voltage [V]	Air Volume \dot{V}_L [m ³ /h] @ $\rho = 1,2 \text{ kg/m}^3$ and Current [A] (bold figures, 2nd. line)							
	Free Air	Total Pressure Δp_t [Pa]						
		100	150	200	250	300	350	400
80	855 2,50	510 2,34	310 2,19	110 2,09				
100	1175 3,14	1040 2,95	940 2,79	830 2,62	690 2,40	530 2,17	300 1,94	
125	1725 3,81	1690 3,72	1590 3,50	1480 3,28	1340 3,02	1150 2,71	830 2,30	280 1,90
150	2285 4,34		2240 4,23	2130 3,97	2000 3,69	1830 3,36	1560 2,93	450 1,96
170	2745 4,60			2640 4,39	2490 4,10	2310 3,78	2040 3,36	950 2,21
190	3110 4,76			3090 4,73	2930 4,44	2730 4,11	2450 3,70	1850 2,97
230	3515 4,72				3490 4,69	3270 4,42	2970 4,06	2480 3,53

**Save power and even more silent with
FISCHBACH SPEED CONTROLLERS
FISCHBACH AUTOMATIC CONTROLLERS**

Voltage Control	Type*	Order-No.*
Stepless, 0 - 100% and 100% - 0	FDR 55	6163
Stepwise, 7 Steps	FDR 750	6202
FISCHBACH AUTOMATIC CONTROL**	FRA 55	6252

* For further details see resp. catalogue pages
** For details of sensors etc., on request

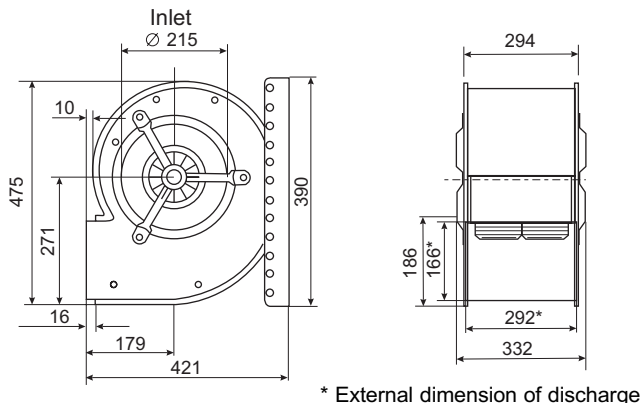

In the above diagram the **TOTAL** pressure (the sum of the dynamic and static pressures) is shown in relation to the air volume, dynamic pressure is shown below system line No.1. Static pressure is shown above that line.

To regain static pressure and reduce dynamic pressure connect a suitable transition piece on the fan outlet.