

Type: DS = Double Inlet

Performance / Dimensions



Type: DS 6-740/D 500 [400V 3N~ 50 Hz]
Protection type: IP 65

For sound data please see extra pages.

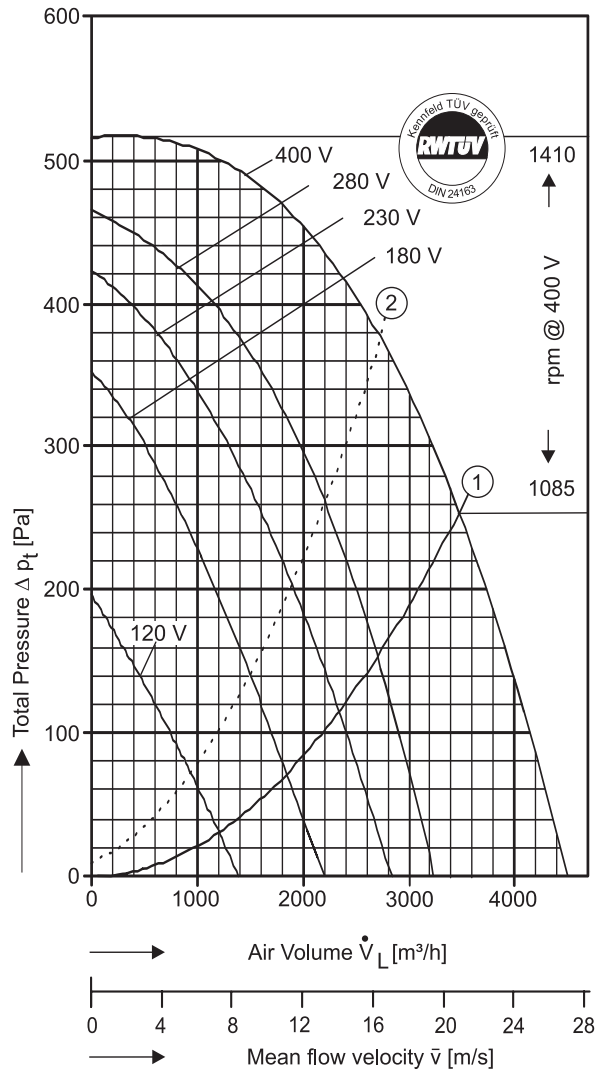

$P_{max} = 1,240 \text{ kW}$ $I_A / I_N = 1,7$ $I_{max} = 2,58 \text{ A}$

- ① System curve for dynamical pressure part related to fan discharge surface of 0,0464 m². For operating points above that curve a max. air temperature of 50° C is allowed (Curve for free blowing fan).
- ② Max. permissible air temperature: 60° C.

Voltage [V]	Air Volume \dot{V}_L [m ³ /h] at $\rho = 1,2 \text{ kg/m}^3$ and current [A] (bold figures, 2nd. line)							
	Free Air	Total Pressure Δp_t [Pa]						
		150	200	250	300	350	400	450
120	1286 1,19	390 0,95						
180	1820 1,57	1450 1,41	1202 1,31	848 1,17	520 1,06			
230	2315 1,84	2148 1,75	1875 1,63	1635 1,53	1334 1,39	851 1,23	453 1,09	
280	2676 2,03		2495 1,92	2260 1,81	1980 1,69	1620 1,57	978 1,37	570 1,22
400	3516 2,58				3169 2,42	2873 2,32	2585 2,22	2121 2,11

Save power and even more silent with FISCHBACH SPEED CONTROLLERS FISCHBACH AUTOMATIC CONTROLLERS

Voltage Control	Type*	Order-No.*
Stepless, 0 - 100% and 100% - 0	FDR 55/3	6231
Stepwise, 5 Steps	FDR 2.75/3	6181
FISCHBACH AUTOMATIC CONTROL **	FRA 55/3	6281
Frequency Inverter FFU	on request	

* For further details see resp. catalogue pages
 ** For details of sensors etc., on request

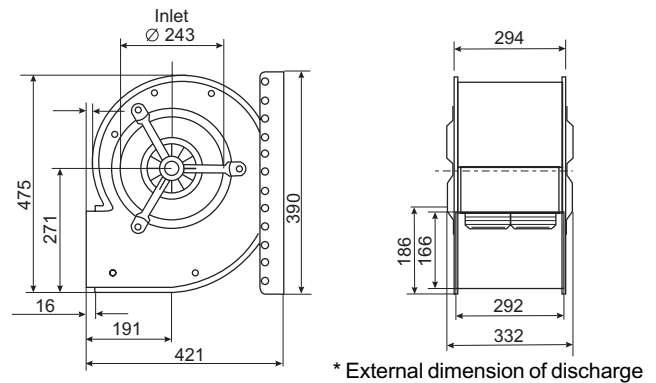

The Silent One

In the above diagram the **TOTAL** pressure (the sum of the dynamic and static pressures) is shown in relation to the air volume, dynamic pressure is shown below system line No.1. Static pressure is shown above that line.