

Series: ROOF TOP UNIT TYPE 41, norm
with FISCHBACH HIGH EFFICIENCY FAN
Type HD

FISCHBACH

Luft- und Ventilatorentechnik GmbH

Type: 41.411 HD560/D5

ERP KONFORM

CE -conform



manufacturer:
Fischbach Luft- und Ventilatorentechnik GmbH
Am Hellerberg 22-24
D-57290 Neunkirchen
phone: ++49(0)2735/777-0
telefax: ++49(0)2735/770-625
internet: www.fischbach-luft.de
email: info@fischbach-luft.de

Technical Data

weight:	(kg)	130
material housing:		aluminum/plastic steel, galvanized
material impeller:		steel, galvanized
direction of rotation:		left
motor protection class:		IP 65
insulation class:		F
motor protection:		thermal contact

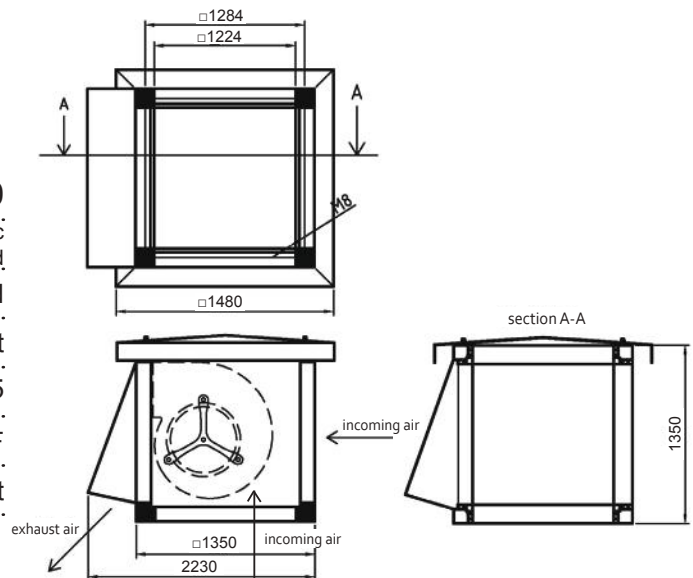

connection plan
0.13-2 I.

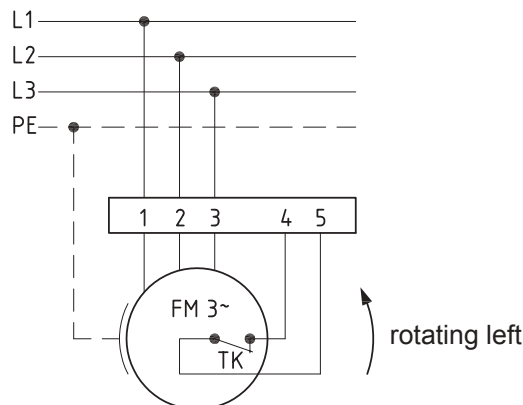

the silent one



Series: **ROOF TOP UNIT TYPE 41, norm**
 with FISCHBACH HIGH EFFICIENCY FAN
 Type HD

FISCHBACH
 Luft- und Ventilatorentechnik GmbH

Type: 41.411 HD560/D5

Erp 2013 2015 x 2018

Performance data

main voltage:	(V)	400 (3~)
frequency:	(Hz)	50
current max.:	(A)	15,1
power input max.:	(kW)	7,8
air flow volume max.:	(m³/h)	26810
statical pressure max.:	(Pa)	1075
speed max.:	(rpm)	1498
supply air temperature:	(°C)	-25... +60
capacitor:	(µF)	-

ErP-Data:

total efficiency fan (η_e):	(%)	59,5
installation category:		A
efficiency category:		static
efficiency grade: N	(%)	61
target efficiency (η_{target}):	(%)	58,3
speed controller		no
year of manufacturing		since 2015
manufacturer:	Fischbach Luft- und Ventilatorentechnik GmbH D-57290 Neunkirchen / HRB 5804 Siegen	
order no.:		18414110
power input:	(kW)	5,53
air flow volume:	(m³/h)	12220
statical pressure:	(Pa)	970
speed:	(rpm)	1410
specific ratio:		1

disassembling/recycling/disposal: see page decommission

installation/operation/maintenance: see operating and mounting instructions

measurement for determination of efficiency without additional items

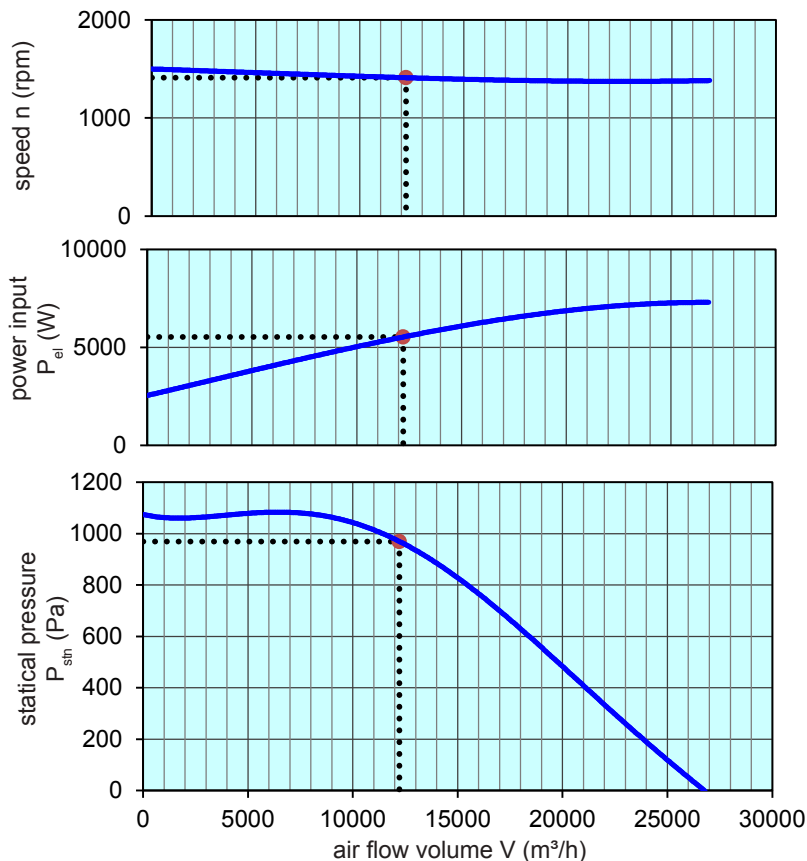

Speed controller / accessories / sound data, please see in the appropriate table

Technical documentation according to page: **General information**